



SSB651 (T610)

Single Channel Bracket

Electro-Galvanized

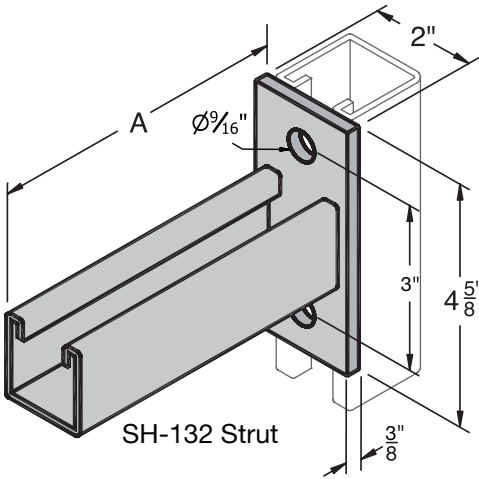

FIG. #	A	STD. PKG.	WEIGHT EACH, LBS.	MAX. REC. LOAD, LBS.
SSB651-6 (T610-6)	6	5	1.85	1200
SSB651-12 (T610-12)	12	10	2.93	600
SSB651-18 (T610-18)	18	10	4.01	400
SSB651-24 (T610-24)	24	5	5.09	300
Mounted to 12 ga. Strut				