



SH142IN

**Concrete Insert 1³/₈ x 1⁵/₈
12 Gauge**

SH142IN Concrete Insert is stocked in pre-galvanized in 10 ft. and 20 ft. lengths. Other materials, finishes and dimensions are available upon request.

LENGTH, IN.	WEIGHT PER 100, LBS.	MAX ALLOWABLE LOAD, LBS.
3	87	500
4	103	800
6	134	1,000
8	206	1,200
12	188	NO MORE THAN 1800 LBS. PER 12" SECTION
18	282	
24	376	
30	470	
36	564	
48	752	
60	940	
72	1,128	
84	1,316	
96	1,504	
108	1,692	
120	1,880	
240	3,760	

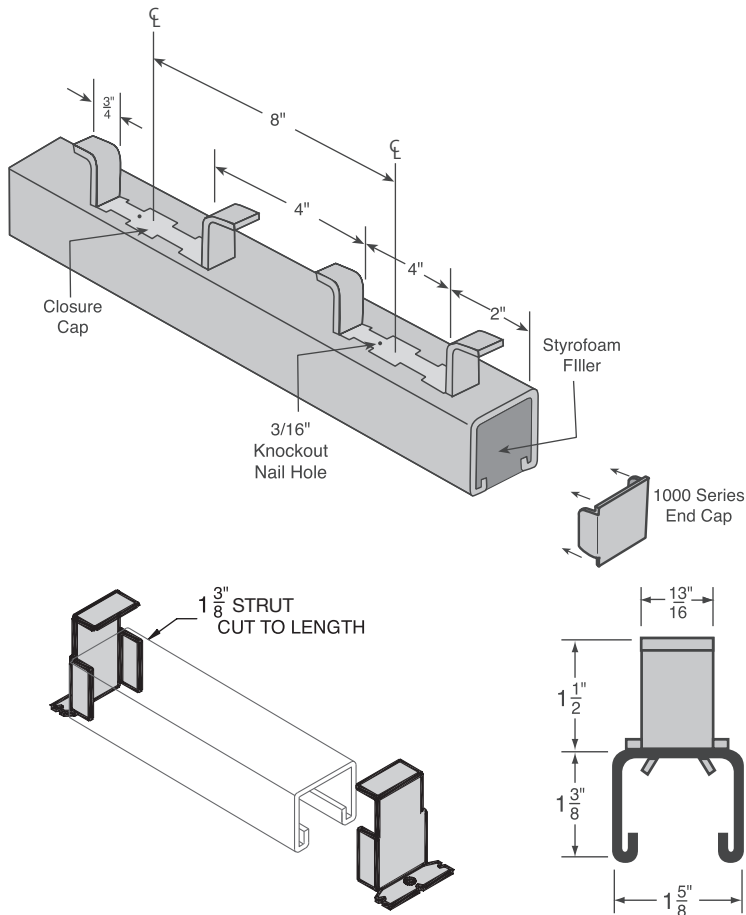

Notes:

- Loading data was calculated in a concrete mixture which was proportioned so that the compression strength of the concrete was 2,500 to 3,000 pounds per square inch and that the load is dependent on the surrounding concrete.
- Tests were performed with a safety factor of 3 and in accordance with the MFMA specifications.
- SH-Strut Concrete Inserts are supplied with either the 1000 or 1001 Series End Cap and either a Styrofoam Filler or Plastic Closure Strip inserted in the strut to prevent any concrete seepage. When ordering, indicate either foam filler or plastic closure strip.
- Inserts should be secured to forms at 16" intervals.