



**SH132IN**

**Concrete Insert 1 5/8 x 1 5/8**  
12 Gauge

SH132IN Concrete Insert is available in pre-galvanized in 10 ft. and 20 ft. lengths. Other materials, finishes and dimensions are available upon request.

LENGTH, IN.	WEIGHT PER 100, LBS.	MAX ALLOWABLE LOAD, LBS.
12	194	NO MORE THAN 2000 LBS. PER 12" SECTION
18	291	
24	388	
30	485	
36	582	
48	776	
60	970	
72	1,164	
84	1,358	
96	1,552	
108	1,746	
120	1,940	
240	3,880	

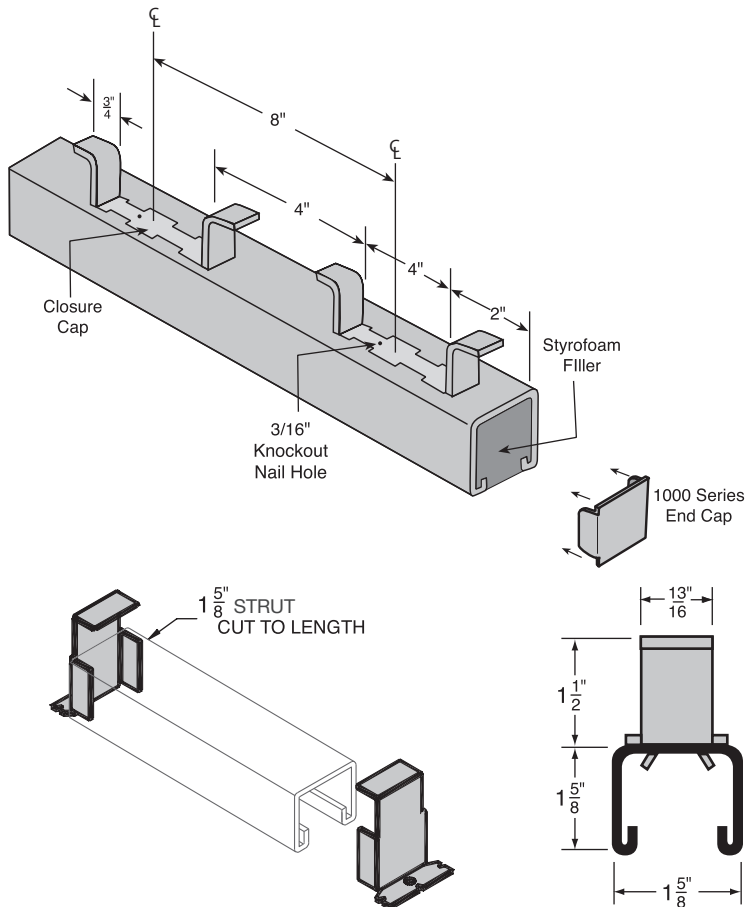

**Notes:**

- Loading data was calculated in a concrete mixture which was proportioned so that the compression strength of the concrete was 2,500 to 3,000 pounds per square inch and that the load is dependent on the surrounding concrete.
- Tests were performed with a safety factor of 3 and in accordance with the MFMA specifications.
- SH-Strut Concrete Inserts are supplied with either the 1000 or 1001 Series End Cap and either a Styrofoam Filler or Plastic Closure Strip inserted in the strut to prevent any concrete seepage. When ordering, indicate either foam filler or plastic closure strip.
- Inserts should be secured to forms at 16" intervals.