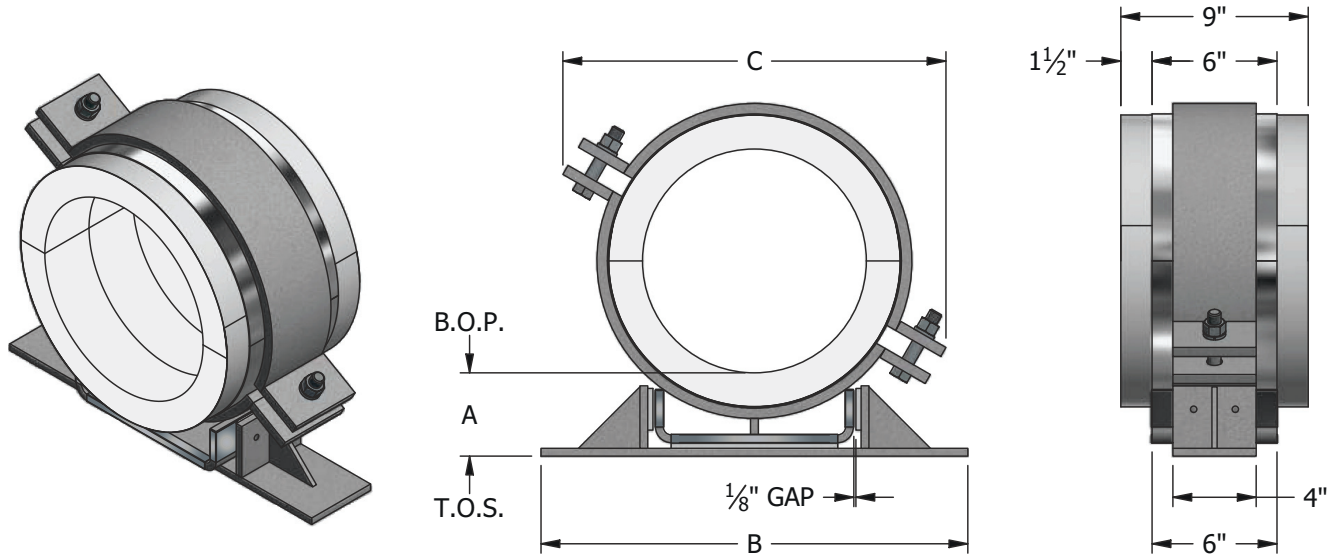



FIG. NG70

Pre-Insulated Guided Pipe Support
 ± 1½" Axial Movement, Laterally Guided - Heavy Duty



Ordering: Fig. NG70 - (Pipe Size) x (Insulation Thickness) - (Insulation Grade)(Finish) e.g. NG70-8x2-5H

PIPE SIZE	VERT. LOAD GRADE 5	VERT. LOAD GRADE 6	INS. THK. = 1"			INS. THK. = 1½"			INS. THK. = 2"			INS. THK. = 2½"			INS. THK. = 3"			INS. THK. = 4"		
			A	B	C	A	B	C	A	B	C	A	B	C	A	B	C	A	B	C
2"	1010	1340	4	8.88	8.81	4	8.44	9.75	5	10.75	10.69	5	10.38	11.56	6	12.81	12.44	6	13.63	14.25
2½"	1230	1640	4	8.81	9.25	4	8.38	10.69	5	10.88	11.56	5	11.31	12.44	6	13.75	13.25	6	13.75	15.13
3"	1430	1900	4	9.56	9.75	4	9.88	10.69	4	9.5	11.56	5	11.94	12.44	6	14.38	13.25	6	14.38	15.13
4"	2250	3000	4	10.88	10.69	4	10.5	11.56	4	10.94	12.44	5	13.38	13.25	6	15.75	14.25	6	15.88	16
5"	2820	3760	4	11.25	12.25	4	11.69	13.06	4	12.13	13.94	5	14.5	14.94	6	16.13	15.81	6	15.94	17.75
6"	3420	4560	4	12.75	13.06	4	13.19	13.94	4	13.56	14.94	5	15.19	15.81	6	17.69	16.69	6	17.5	18.63
8"	4500	6000	4	15.56	14.94	4	15.19	15.81	4	15.69	16.69	6	19	17.75	6	19.5	18.63	6	19.63	20.38
10"	5400	7200	4	17.31	17.31	4	16.63	18.38	4	17.13	19.25	6	20.75	20.13	6	21.25	21	6	20.5	22.75
12"	5850	7800	4	19.13	19.25	4	18.75	20.13	4	19.25	21	6	22.88	21.88	6	22.5	22.75	6	22.63	24.5
14"	6750	9000	4	20	20.13	4	20.5	21	4	20.13	21.88	6	23.75	22.75	6	24.25	23.63	6	24.38	25.31
16"	7800	10400	4	21.88	23.19	4	21.5	24.06	6	26	24.94	6	25.63	25.81	6	26.13	26.69	8	29.38	28.38
18"	8550	11400	4	24	24.94	4	23.63	25.81	6	28.13	26.69	6	27.75	27.5	6	27.38	28.38	8	31.5	30.13
20"	9150	12200	4	26.13	26.69	4	25.75	27.5	6	29.38	28.38	6	29.88	29.25	6	29.5	30.13	8	33.63	31.88
24"	9600	12800	4	29.5	30.13	4	30	31	6	33.63	31.88	6	34.19	32.75	6	33.75	33.63	8	37.94	35.31
30"	12600	16800	4	35.63	35.81	6	39.25	36.63	6	39.81	37.5	6	39.38	38.38	6	39	39.25	8	43.19	41
36"	14700	19600	4	40.56	43.63	6	45.06	44.5	6	44.69	45.38	6	44.31	46.25	6	44.88	47.13	8	49	48.81
42"	16650	22200	4	47	48.81	6	50.63	49.69	6	51.13	50.56	6	50.75	51.44	6	50.38	52.31	8	54.5	54.06

<p>Applications:</p> <ul style="list-style-type: none"> • Allows guided moderate axial travel while providing heavy duty lateral support and vertical support • Designed for use on: Chilled Water Hot Water Steam • Installation: welded to flat steel surface • Temperature Range: +20°F to +1200°F • Axial Travel: ± 1½" • Lateral Guide Gap: ± 1/8" 	<p>Features:</p> <ul style="list-style-type: none"> • Allowable Lateral Load = 50% of Vertical Load • Eliminates welding to pipe • Provides continuous, zero permeability vapor barrier • Insulation extends beyond shield 1½" each side • Structural insulation for load transfer • Stainless steel to UHMW polyethylene slide • Static Coefficient of Friction = 0.15 • ASTM E-84 Flame Spread/Smoke Developed: 10/20 • Thermal Conductivity Grade 5 = 0.54 Btu•in/(hr•ft²•°F) @ 200°F Grade 6 = 0.61 Btu•in/(hr•ft²•°F) @ 200°F • Insulation chemically bonded 	<p>Material Data:</p> <p>Insulation: Calcium Silicate meeting ASTM C-585 and C-656 Type II Grade 5: 450 psi, 20 pcf Grade 6: 900 psi, 28 pcf other insulation materials, Page 34</p> <p>Base/Clamp: ASTM A-36 Carbon Steel Fasteners: ASTM A-307 Electro-Galv. Plated Slide: ASTM A-240 Type 304 Stainless Steel on UHMW Polyethylene Shield: ASTM A-653 G-90, 18 ga Galv. Steel Vapor Barrier: ASTM E-96 All Service Jacket Finishes: (H) Hot-Dip Galv. per ASTM A-123 (B) Unfinished</p>
--	--	--