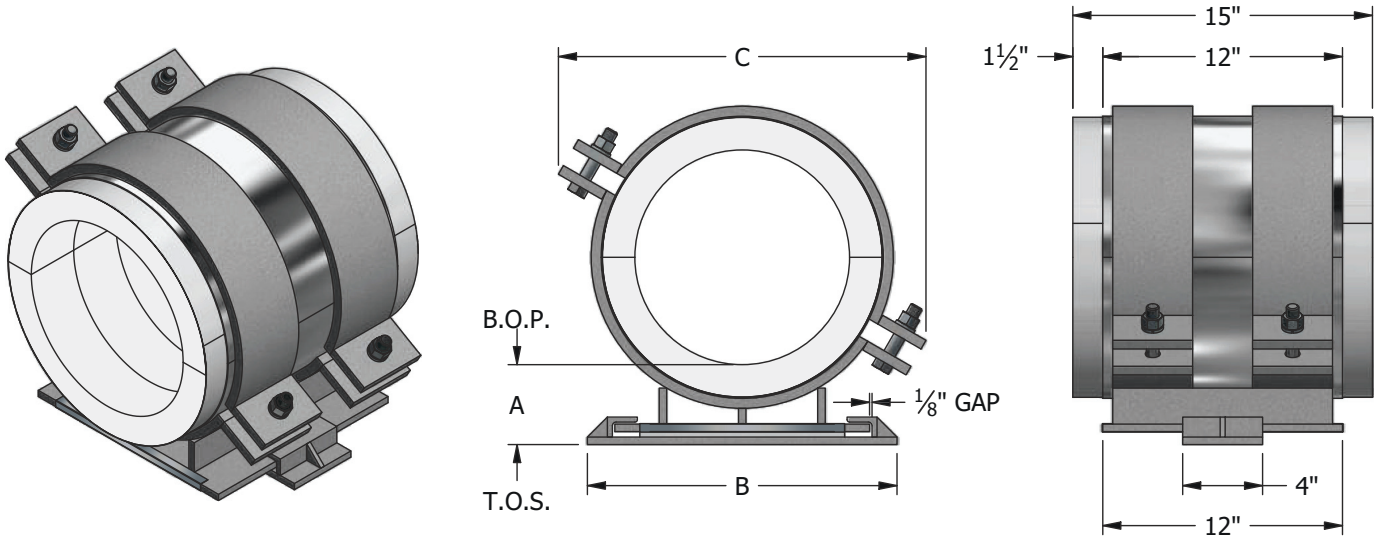

**FIG. NG40**

**Pre-Insulated Guided Pipe Support**  
 ± 4 1/2" Axial Movement, Laterally Guided - Light Duty



**Ordering:** Fig. NG40 - (Pipe Size) x (Insulation Thickness) - (Insulation Grade)(Finish) e.g. NG40-8x2-5H

PIPE SIZE	VERT. LOAD GRADE 5	VERT. LOAD GRADE 6	INS. THK. = 1"			INS. THK. = 1 1/2"			INS. THK. = 2"			INS. THK. = 2 1/2"			INS. THK. = 3"			INS. THK. = 4"		
			A	B	C	A	B	C	A	B	C	A	B	C	A	B	C	A	B	C
2"	1100	1500	4	7	8.81	4	7.5	9.75	5	8.5	10.69	5	9	11.56	6	10	12.44	6	12	14.25
2 1/2"	1350	1800	4	7	9.25	4	8.5	10.69	5	9	11.56	5	10	12.44	6	11	13.25	6	12.5	15.13
3"	1600	2100	4	7.5	9.75	4	8.5	10.69	4	9	11.56	5	10	12.44	6	11	13.25	6	12.5	15.13
4"	2500	3350	4	8.5	10.69	4	9	11.56	4	10	12.44	5	11	13.25	6	12	14.25	6	13.5	16
5"	3100	4200	4	10	12.25	4	11	13.06	4	12	13.94	5	13	14.94	6	13.5	15.81	6	15	17.75
6"	3800	5100	4	11	13.06	4	12	13.94	4	13	14.94	5	13.5	15.81	6	14.5	16.69	6	16	18.63
8"	5100	6800	4	13.5	14.94	4	14	15.81	4	15	16.69	6	15.5	17.75	6	16.5	18.63	6	18	20.38
10"	6000	8000	4	15	17.31	4	15.5	18.38	4	16.5	19.25	6	17	20.13	6	18	21	6	19	22.75
12"	6600	8800	4	17	19.25	4	17.5	20.13	4	18.5	21	6	19	21.88	6	19.5	22.75	6	21	24.5
14"	7500	10000	4	17.5	20.13	4	18.5	21	4	19	21.88	6	19.5	22.75	6	20.5	23.63	6	22	25.31
16"	8700	11600	4	20.5	23.19	4	21	24.06	6	22	24.94	6	22.5	25.81	6	23.5	26.69	8	24.5	28.38
18"	9600	12800	4	22	24.94	4	22.5	25.81	6	23.5	26.69	6	24	27.5	6	24.5	28.38	8	26	30.13
20"	10200	13600	4	23.5	26.69	4	24	27.5	6	24.5	28.38	6	25.5	29.25	6	26	30.13	8	27.5	31.88
24"	10800	14400	4	26	30.13	4	27	31	6	27.5	31.88	6	28.5	32.75	6	29	33.63	8	30.5	35.31
30"	14100	18800	4	32.5	35.81	6	33	36.63	6	34	37.5	6	34.5	38.38	6	35	39.25	8	36.5	41
36"	16500	22000	4	36.5	43.63	6	37.5	44.5	6	38	45.38	6	38.5	46.25	6	39.5	47.13	8	41	48.81
42"	18600	24800	4	41	48.81	6	41.5	49.69	6	42.5	50.56	6	43	51.44	6	43.5	52.31	8	45	54.06

<p><b>Applications:</b></p> <ul style="list-style-type: none"> <li>Allows guided large axial travel while providing light duty lateral support for buckling and movement control and vertical support</li> <li>Designed for use on: Chilled Water   Hot Water   Steam</li> <li>Installation: welded to flat steel surface</li> <li>Temperature Range: +20°F to +1200°F</li> <li>Axial Travel: ± 4 1/2"</li> <li>Lateral Guide Gap: ± 1/8"</li> </ul>	<p><b>Features:</b></p> <ul style="list-style-type: none"> <li>Allowable Lateral Load = 20% of Vertical Load</li> <li>Eliminates welding to pipe</li> <li>Provides continuous, zero permeability vapor barrier</li> <li>Insulation extends beyond shield 1 1/2" each side</li> <li>Structural insulation for load transfer</li> <li>Stainless steel to UHMW polyethylene slide</li> <li>Static Coefficient of Friction = 0.15</li> <li>ASTM E-84 Flame Spread/Smoke Developed: 10/20</li> <li>Thermal Conductivity Grade 5 = 0.54 Btu•in/(hr•ft²•°F) @ 200°F Grade 6 = 0.61 Btu•in/(hr•ft²•°F) @ 200°F</li> <li>Insulation chemically bonded</li> </ul>	<p><b>Material Data:</b></p> <p>Insulation: Calcium Silicate meeting ASTM C-585 and C-656 Type II              Grade 5: 450 psi, 20 pcf              Grade 6: 900 psi, 28 pcf              other insulation materials, Page 34</p> <p>Base/Clamp: ASTM A-36 Carbon Steel              Fasteners: ASTM A-307 Electro-Galv. Plated              Slide: ASTM A-240 Type 304 Stainless Steel on UHMW Polyethylene              Shield: ASTM A-653 G-90, 18 ga Galv. Steel              Vapor Barrier: ASTM E-96 All Service Jacket              Finishes: (H) Hot-Dip Galv. per ASTM A-123              (B) Unfinished</p>
--	---	--