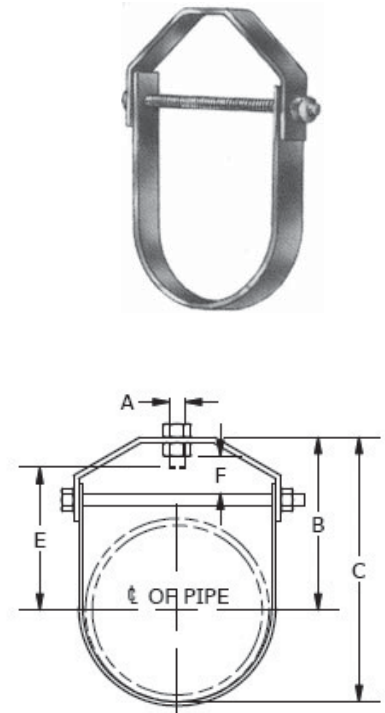

FIG. CT200**COPPER TUBING CLEVIS HANGER**

MATERIAL: Carbon steel.
FINISH: Copper plated.
SERVICE: For the suspension of stationary copper tubing lines.
ORDERING: Specify tubing size and figure number.
APPROVALS: FS WW-H-171E TYPE 12.

TUBING SIZE	MATERIAL SIZE		A	B	C	E	F	WEIGHT EACH, LBS.
	UPPER	LOWER						
1/2	18ga. x 7/8	18ga. x 7/8	3/8	1 7/8	2 3/16	1 1/2	1/2	.12
3/4	18ga. x 7/8	18ga. x 7/8	3/8	1 3/4	2 1/8	1 3/8	1/2	.12
1	18ga. x 7/8	18ga. x 7/8	3/8	1 13/16	2 5/16	1 7/16	1/2	.14
1 1/4	18ga. x 7/8	18ga. x 7/8	3/8	2 1/8	2 3/4	1 11/16	3/4	.17
1 1/2	18ga. x 7/8	18ga. x 7/8	3/8	2 1/2	3 1/4	2 1/8	15/16	.20
2	14ga. x 7/8	16ga. x 7/8	3/8	2 15/16	4	2 9/16	1 1/16	.38
2 1/2	12ga. x 1 3/16	14ga. x 1 3/16	1/2	4 7/8	5 3/4	3 7/8	2 1/16	.71
3	12ga. x 1 3/16	14ga. x 1 3/16	1/2	4 1/2	6 1/8	3 15/16	2	.76
3 1/2	12ga. x 1 3/16	14ga. x 1 3/16	1/2	5 9/16	7 7/8	5	2 5/8	.82
4	11ga. x 1 3/16	14ga. x 1 3/16	1/2	5 7/8	7 7/8	5 1/4	2 9/16	1.02
5	8ga. x 1 1/4	8ga. x 1 1/4	5/8	5 7/8	8 3/4	5 3/8	1 5/8	1.68
6	8ga. x 1 1/4	8ga. x 1 1/4	5/8	6 1/16	9	5 3/8	1 1/2	1.84

**FIG. CT420****COPPER TUBING RISER CLAMP**

MATERIAL: Carbon steel.
FINISH: Copper plated.
SERVICE: For support of tubing risers.
ORDERING: Specify tubing size and figure number.
APPROVALS: MSS SP-58 & SP-69 TYPE 8
 FS WW-H-171E TYPE 8

NOMINAL TUBING SIZE	A	MATERIAL SIZE	REC. LOAD LBS.	WEIGHT EACH, LBS.
1/2	6 3/4	1/8 x 1	225	.69
3/4	7 1/16	1/8 x 1	225	.73
1	9 1/4	1/8 x 1	250	.75
1 1/4	9 5/8	1/8 x 1	250	.77
1 1/2	10 1/8	1/8 x 1	500	.80
2	10 3/4	1/8 x 1 1/4	500	1.05
2 1/2	11 1/4	3/16 x 1 1/4	500	1.68
3	11 1/2	3/16 x 1 1/4	500	1.78
3 1/2	12 1/4	3/16 x 1 1/4	500	1.91
4	12 3/4	3/16 x 1 1/4	500	2.05
5	14	1/4 x 1 1/2	815	3.46
6	15 1/2	1/4 x 1 1/2	815	3.86

